

## MULTIPOINT-LVDS QUAD DIFFERENTIAL LINE DRIVER

### FEATURES

- Differential Line Drivers for 30-Ω to 55-Ω Loads and Data Rates<sup>(1)</sup> Up to 200 Mbps, Clock Frequencies up to 100 MHz
- Supports Multipoint Bus Architectures
- Meets the Requirements of TIA/EIA-899
- Operates from a Single 3.3-V Supply
- Characterized for Operation from –40°C to 85°C
- 16-Pin SOIC (JEDEC MS-012) and 16-Pin TSSOP (JEDEC MS-153) Packaging

### APPLICATIONS

- AdvancedTCA™ (ATCA™) Clock Bus Driver
- Clock Distribution
- Backplane or Cabled Multipoint Data Transmission in Telecommunications, Automotive, Industrial, and Other Computer Systems
- Cellular Base Stations
- Central-Office and PBX Switching
- Bridges and Routers
- Low-Power High-Speed Short-Reach Alternative to TIA/EIA-485

### DESCRIPTION

The SN65MLVD047A is a quadruple line driver that complies with the TIA/EIA-899 standard, Electrical Characteristics of Multipoint-Low-Voltage Differential Signaling (M-LVDS). The output current of this M-LVDS device has been increased, in comparison to standard LVDS compliant devices, in order to support doubly terminated transmission lines and heavily loaded backplane bus applications. Backplane applications generally require impedance matching termination resistors at both ends of the bus. The effective impedance of a doubly terminated bus can be as low as 30 Ω due to the bus terminations, as well as the capacitive load of bus interface devices. SN65MLVD047A drivers allow for operation with loads as low as 30 Ω. The SN65MLVD047A devices allow for multiple drivers to be present on a single bus. SN65MLVD047A drivers are high impedance when disabled or unpowered. Driver edge rate control is incorporated to support operation. The M-LVDS standard allows up to 32 nodes (drivers and/or receivers) to be connected to the same media in a backplane when multiple bus stubs are expected from the main transmission line to interface devices. The SN65MLVD047A provides 9-kV ESD protection on all bus pins.

### LOGIC DIAGRAM (POSITIVE LOGIC)

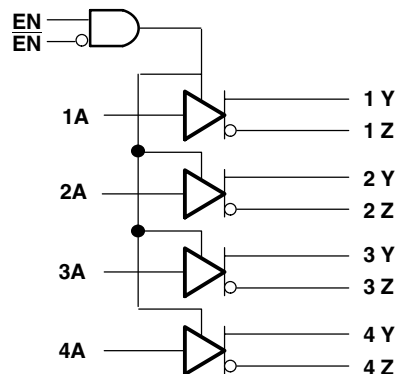

Please be aware that an important notice concerning availability, standard warranty, and use in critical applications of Texas Instruments semiconductor products and disclaimers thereto appears at the end of this data sheet.

<sup>(1)</sup>The data rate of a line, is the number of voltage transitions that are made per second expressed in the units bps (bits per second).

AdvancedTCA and ATCA are trademarks of the PCI Industrial Computer Manufacturers Group.



These devices have limited built-in ESD protection. The leads should be shorted together or the device placed in conductive foam during storage or handling to prevent electrostatic damage to the MOS gates.

**ORDERING INFORMATION**

PART NUMBER	PACKAGE MARKING	PACKAGE/CARRIER
SN65MLVD047AD	MLVD047A	16-Pin SOIC/Tube
SM65MLVD047ADR	MLVD047A	16-Pin SOIC/Tape and Reel
SN65MLVD047APW	BUL	16-Pin TSSOP/Tube
SM65MLVD047APWR	BUL	16-Pin TSSOP/Tape and Reel

NOTE: For the most current package and ordering information, see the Package Option Addendum at the end of this document, or see the TI website at www.ti.com.

**PACKAGE DISSIPATION RATINGS**

PACKAGE	PCB JEDEC STANDARD	T <sub>A</sub> ≤ 25°C POWER RATING	DERATING FACTOR ABOVE T <sub>A</sub> = 25°C <sup>(1)</sup>	T <sub>A</sub> = 85°C POWER RATING
D(16)	Low-K <sup>(2)</sup>	898 mW	7.81 mW/°C	429 mW
PW(16)	Low-K <sup>(2)</sup>	592 mW	5.15 mW/°C	283 mw
	High-K <sup>(3)</sup>	945 mW	8.22 mW/°C	452 mw

<sup>(1)</sup> This is the inverse of the junction-to-ambient thermal resistance when board mounted and with no air flow.

<sup>(2)</sup> In accordance with the Low-K thermal metric definitions of EIA/JESD51–3.

<sup>(3)</sup> In accordance with the High-K thermal metric definitions of EIA/JESD51–7.

**ABSOLUTE MAXIMUM RATINGS**

over operating free-air temperature range unless otherwise noted<sup>(1)</sup>

		UNITS	
Supply voltage range <sup>(2)</sup> , V <sub>CC</sub>		–0.5 V to 4 V	
Input voltage range, V <sub>I</sub>	A, EN, $\bar{E}\bar{N}$	–0.5 V to 4 V	
Output voltage range, V <sub>O</sub>	Y, Z	–1.8 V to 4 V	
Electrostatic discharge	Human Body Model <sup>(3)</sup>	Y and Z	±9 kV
		All pins	±4 kV
	Charged-Device Model <sup>(4)</sup>	All pins	±1500 V
	Machine Model <sup>(5)</sup>	All pins	200 V
Junction temperature, T <sub>J</sub>		140°C	

<sup>(1)</sup> Stresses beyond those listed under “absolute maximum ratings” may cause permanent damage to the device. These are stress ratings only, and functional operation of the device at these or any other conditions beyond those indicated under “recommended operating conditions” is not implied. Exposure to absolute-maximum-rated conditions for extended periods may affect device reliability.

<sup>(2)</sup> All voltage values, except differential I/O bus voltages, are with respect to the circuit ground terminal.

<sup>(3)</sup> Tested in accordance with JEDEC Standard 22, Test Method A114–B.

<sup>(4)</sup> Tested in accordance with JEDEC Standard 22, Test Method C101–A.

<sup>(5)</sup> Tested in accordance with JEDEC Standard 22, Test Method A115–A.

**RECOMMENDED OPERATING CONDITIONS** (see Figure 1)

	MIN	NOM	MAX	UNIT
Supply voltage, $V_{CC}$	3	3.3	3.6	V
High-level input voltage, $V_{IH}$	2		$V_{CC}$	V
Low-level input voltage, $V_{IL}$	0		0.8	V
Voltage at any bus terminal (separate or common mode) $V_Y$ or $V_Z$	-1.4		3.8	V
Differential load resistance, $R_L$	30		55	$\Omega$
Signaling rate, $1/t_{UI}$			200	Mbps
Clock frequency, $f$			100	MHz
Junction temperature, $T_J$	-40		125	$^{\circ}\text{C}$

**THERMAL CHARACTERISTICS**

PARAMETER	TEST CONDITIONS	MIN	TYP	MAX	UNIT
Junction-to-ambient thermal resistance, $\theta_{JA}$	Low-K board <sup>(1)</sup> , no airflow	D	128		$^{\circ}\text{C}/\text{W}$
	Low-K board <sup>(1)</sup> , no airflow	PW	194.2		
	Low-K board <sup>(1)</sup> , 150 LFM		146.8		
	Low-K board <sup>(1)</sup> , 250 LFM		133.1		
	High-K board <sup>(2)</sup> , no airflow			121.6	
Junction-to-board thermal resistance, $\theta_{JB}$	High-K board <sup>(2)</sup>	D	51.1		$^{\circ}\text{C}/\text{W}$
		PW	85.3		
Junction-to-case thermal resistance, $\theta_{JC}$		D	45.4		$^{\circ}\text{C}/\text{W}$
		PW	34.7		
Device power dissipation, $P_D$	EN = $V_{CC}$ , $\overline{\text{EN}}$ = GND, $R_L = 50 \Omega$ , Input 100 MHz 50 % duty cycle square wave to all data inputs, $T_A = 85^{\circ}\text{C}$			288.5	mW

(1) In accordance with the Low-K thermal metric definitions of EIA/JESD51-3.

(2) In accordance with the High-K thermal metric definitions of EIA/JESD51-7.

**ELECTRICAL CHARACTERISTICS**

over recommended operating conditions unless otherwise noted

PARAMETER	TEST CONDITIONS	MIN	TYP <sup>(1)</sup>	MAX	UNIT
$I_{CC}$ Supply current	Driver enabled	EN = $V_{CC}$ , $\overline{\text{EN}}$ = GND, $R_L = 50 \Omega$ , All data inputs = $V_{CC}$ or GND	59	70	mA
	Driver disabled	EN = GND, $\overline{\text{EN}}$ = $V_{CC}$ , $R_L =$ No load, All data inputs = $V_{CC}$ or GND	2	4	

(1) All typical values are at 25 $^{\circ}\text{C}$  and with a 3.3-V supply voltage.

**ELECTRICAL CHARACTERISTICS**

over recommended operating conditions unless otherwise noted

PARAMETER		TEST CONDITIONS	MIN <sup>(1)</sup>	TYP <sup>(2)</sup>	MAX	UNIT
LVTTTL (EN, $\overline{\text{EN}}$ , 1A:4A)						
$ I_{IH} $	High-level input current	$V_{IH} = 2 \text{ V or } V_{CC}$	0		10	$\mu\text{A}$
$ I_{IL} $	Low-level input current	$V_{IL} = \text{GND or } 0.8 \text{ V}$	0		10	$\mu\text{A}$
$C_i$	Input capacitance	$V_I = 0.4 \sin(30E6\pi t) + 0.5 \text{ V}^{(3)}$		5		pF
M-LVDS (1Y/1Z:4Y/4Z)						
$ V_{YZ} $	Differential output voltage magnitude	See Figure 2	480		650	mV
$\Delta V_{YZ} $	Change in differential output voltage magnitude between logic states		-50		50	mV
$V_{OS(SS)}$	Steady-state common-mode output voltage	See Figure 3	0.8		1.2	V
$\Delta V_{OS(SS)}$	Change in steady-state common-mode output voltage between logic states		-50		50	mV
$V_{OS(PP)}$	Peak-to-peak common-mode output voltage				150	mV
$V_{Y(OC)}$	Maximum steady-state open-circuit output voltage	See Figure 7	0		2.4	V
$V_{Z(OC)}$	Maximum steady-state open-circuit output voltage		0		2.4	V
$V_{P(H)}$	Voltage overshoot, low-to-high level output	See Figure 5			$1.2 V_{SS}$	V
$V_{P(L)}$	Voltage overshoot, high-to-low level output		$-0.2 V_{SS}$			V
$ I_{OS} $	Differential short-circuit output current magnitude	See Figure 4			24	mA
$I_{OZ}$	High-impedance state output current	$-1.4 \text{ V} \leq (V_Y \text{ or } V_Z) \leq 3.8 \text{ V}$ , Other output = 1.2 V	-15		10	$\mu\text{A}$
$I_{O(OFF)}$	Power-off output current	$-1.4 \text{ V} \leq (V_Y \text{ or } V_Z) \leq 3.8 \text{ V}$ , Other output = 1.2 V, $V_{CC} \leq 1.5 \text{ V}$	-10		10	$\mu\text{A}$
$C_Y$ or $C_Z$	Output capacitance	$V_Y$ or $V_Z = 0.4 \sin(30E6\pi t) + 0.5 \text{ V}$ , <sup>(3)</sup> Other outputs at 1.2 V, driver disabled		3		pF
$C_{YZ}$	Differential output capacitance	$V_{YZ} = 0.4 \sin(30E6\pi t) \text{ V}$ , <sup>(3)</sup> Driver disabled			2.5	pF
$C_{Y/Z}$	Output capacitance balance, ( $C_Y/C_Z$ )		0.99		1.01	

(1) The algebraic convention, in which the least positive (most negative) limit is designated as minimum is used in this data sheet.

(2) All typical values are at 25°C and with a 3.3-V supply voltage.

(3) HP4194A impedance analyzer (or equivalent)

**SWITCHING CHARACTERISTICS**

over recommended operating conditions unless otherwise noted

PARAMETER		TEST CONDITIONS	MIN	TYP <sup>(1)</sup>	MAX	UNIT
$t_{pLH}$	Propagation delay time, low-to-high-level output	See Figure 5	1	1.5	2.4	ns
$t_{pHL}$	Propagation delay time, high-to-low-level output		1	1.5	2.4	ns
$t_r$	Differential output signal rise time		1		1.9	ns
$t_f$	Differential output signal fall time		1		1.9	ns
$t_{sk(o)}$	Output skew <sup>(2)</sup>				100	ps
$t_{sk(p)}$	Pulse skew ( $ t_{pHL} - t_{pLH} $ )			22	100	ps
$t_{sk(pp)}$	Part-to-part skew <sup>(3)</sup>				600	ps
$t_{jit(per)}$	Period jitter, rms (1 standard deviation) <sup>(4)</sup>	See Figure 8, All data inputs 100 MHz clock input		0.2	1	ps
$t_{jit(c-c)}$	Cycle-to-cycle jitter <sup>(4)</sup>	See Figure 8, All data inputs 100 MHz clock input		5	36	ps
$t_{jit(pp)}$	Peak-to-peak jitter <sup>(3)(5)</sup>	See Figure 8, All data inputs 200 Mbps 2 <sup>15</sup> -1 PRBS input		46	158	ps
$t_{pZH}$	Enable time, high-impedance-to-high-level output	See Figure 6			9	ns
$t_{pZL}$	Enable time, high-impedance-to-low-level output				9	ns
$t_{pHZ}$	Disable time, high-level-to-high-impedance output	See Figure 6			10	ns
$t_{pLZ}$	Disable time, low-level-to-high-impedance output				10	ns

<sup>(1)</sup> All typical values are at 25°C and with a 3.3-V supply voltage.

<sup>(2)</sup>  $t_{sk(o)}$ : output skew is the magnitude of the time difference in propagation delay times between any specified terminals of a device.

<sup>(3)</sup>  $t_{sk(pp)}$  is the magnitude of the difference in propagation delay times between any specified terminals of two devices when both devices operate with the same supply voltages, at the same temperature, and have identical packages and test circuits.

<sup>(4)</sup> Stimulus jitter has been subtracted from the measurements.

<sup>(5)</sup> Peak-to-peak jitter includes jitter due to pulse skew ( $t_{sk(p)}$ ).

PARAMETER MEASUREMENT INFORMATION

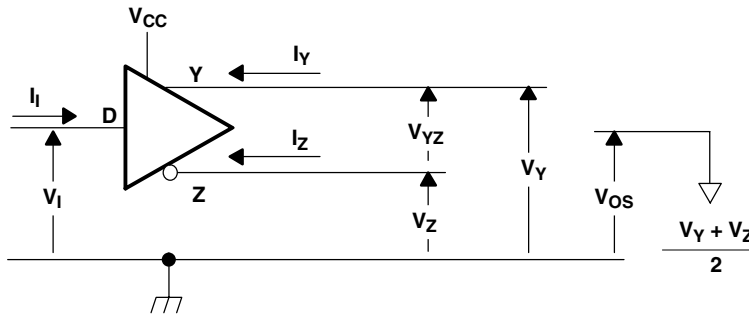
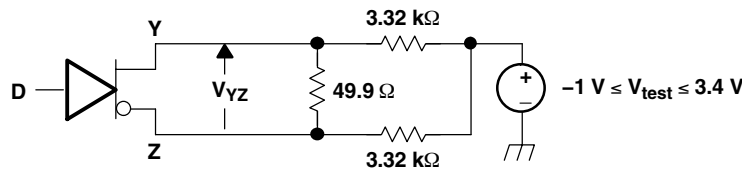
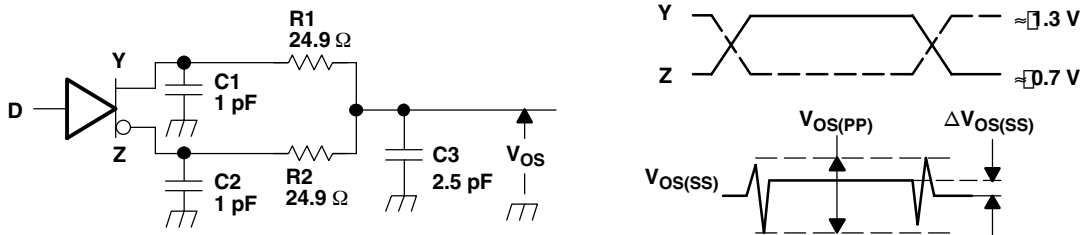

Figure 1. Driver Voltage and Current Definitions



NOTE: All resistors are 1% tolerance.

Figure 2. Differential Output Voltage Test Circuit



- NOTES:
- A. All input pulses are supplied by a generator having the following characteristics:  $t_r$  or  $t_f \leq 1$  ns, pulse frequency = 500 kHz, duty cycle =  $50 \pm 5\%$ .
  - B. C1, C2 and C3 include instrumentation and fixture capacitance within 2 cm of the D.U.T. and are  $\pm 20\%$ .
  - C. R1 and R2 are metal film, surface mount,  $\pm 1\%$ , and located within 2 cm of the D.U.T.
  - D. The measurement of  $V_{OS(PP)}$  is made on test equipment with a  $-3$  dB bandwidth of at least 1 GHz.

Figure 3. Test Circuit and Definitions for the Common-Mode Output Voltage

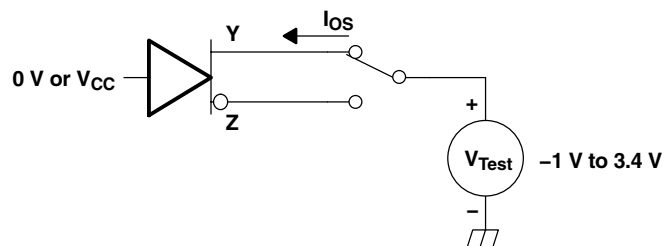
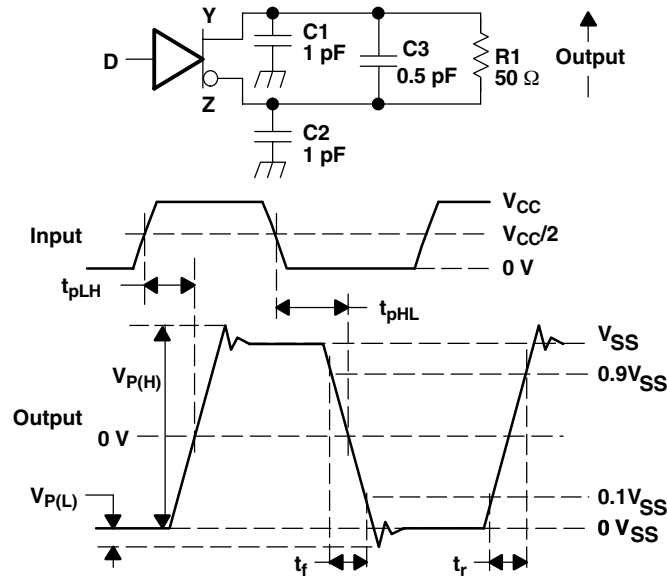
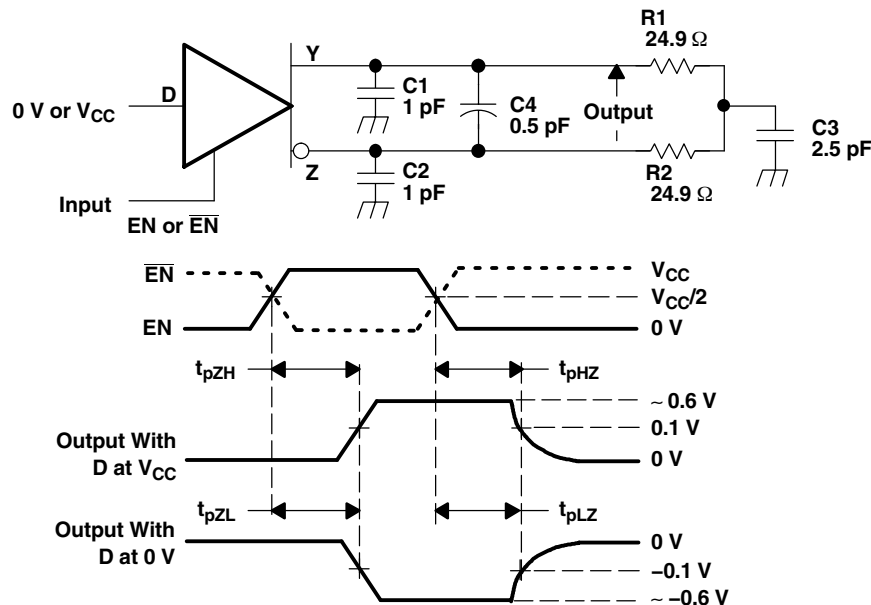

Figure 4. Short-Circuit Test Circuit



- NOTES: A. All input pulses are supplied by a generator having the following characteristics:  $t_r$  or  $t_f \leq 1$  ns, frequency = 500 kHz, duty cycle =  $50 \pm 5\%$ .  
 B. C1, C2, and C3 include instrumentation and fixture capacitance within 2 cm of the D.U.T. and are  $\pm 20\%$ .  
 C. R1 is a metal film, surface mount, and 1% tolerance and located within 2 cm of the D.U.T.  
 D. The measurement is made on test equipment with a  $-3$  dB bandwidth of at least 1 GHz.

Figure 5. Driver Test Circuit, Timing, and Voltage Definitions for the Differential Output Signal



- NOTES: A. All input pulses are supplied by a generator having the following characteristics:  $t_r$  or  $t_f \leq 1$  ns, frequency = 500 kHz, duty cycle =  $50 \pm 5\%$ .  
 B. C1, C2, C3, and C4 includes instrumentation and fixture capacitance within 2 cm of the D.U.T. and are  $\pm 20\%$ .  
 C. R1 and R2 are metal film, surface mount, and 1% tolerance and located within 2 cm of the D.U.T.  
 D. The measurement is made on test equipment with a  $-3$  dB bandwidth of at least 1 GHz.

Figure 6. Driver Enable and Disable Time Circuit and Definitions

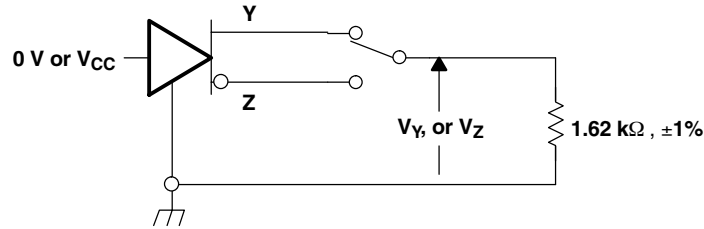
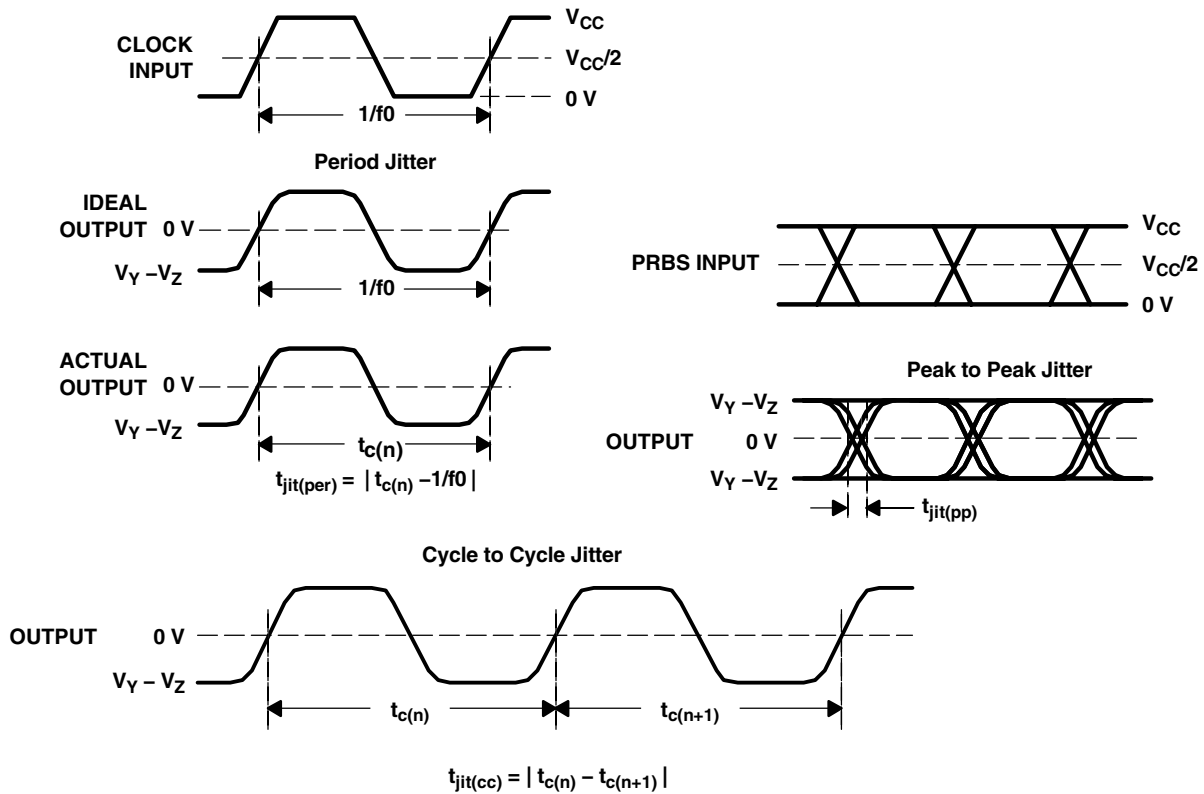

Figure 7. Driver Maximum Steady State Output Voltage



- NOTES:A. All input pulses are supplied by an Agilent 8304A Stimulus System.  
 B. The measurement is made on a TEK TDS6604 running TDSJIT3 application software  
 C. Period jitter and cycle-to-cycle jitter are measured using a 100 MHz 50 ±1% duty cycle clock input.  
 D. Peak-to-peak jitter is measured using a 200 Mbps 2<sup>15</sup>-1 PRBS input.

Figure 8. Driver Jitter Measurement Waveforms



**DEVICE INFORMATION**

**PIN ASSIGNMENTS**

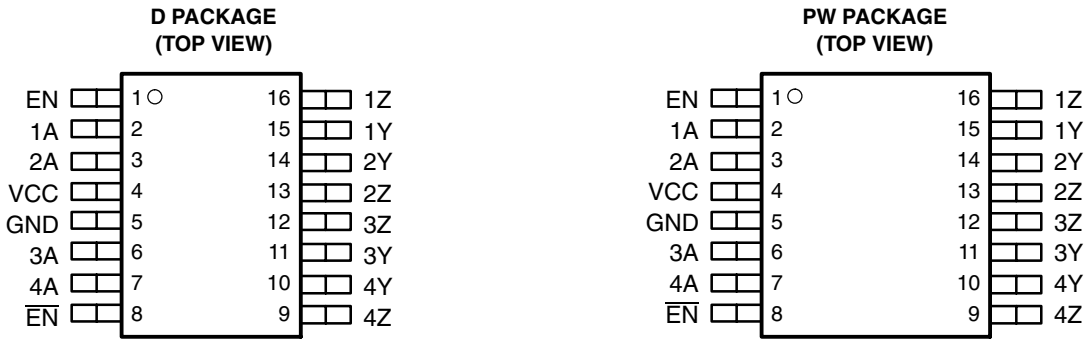

**DEVICE FUNCTION TABLE**

INPUTS			OUTPUTS	
D	EN	$\overline{\text{EN}}$	Y	Z
L	H	L	L	H
H	H	L	H	L
OPEN	H	L	L	H
X	L or OPEN	X	Z	Z
X	X	H or OPEN	Z	Z

H = high level, L = low level, Z = high impedance, X = Don't care

**EQUIVALENT INPUT AND OUTPUT SCHEMATIC DIAGRAMS**

**DRIVER INPUT AND ACTIVE-HIGH ENABLE**

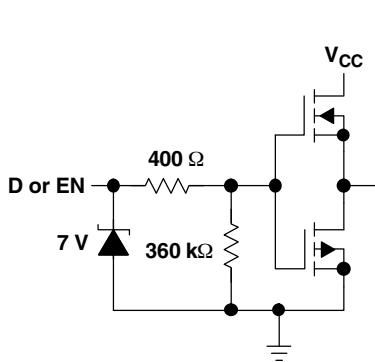

**DRIVER OUTPUT**

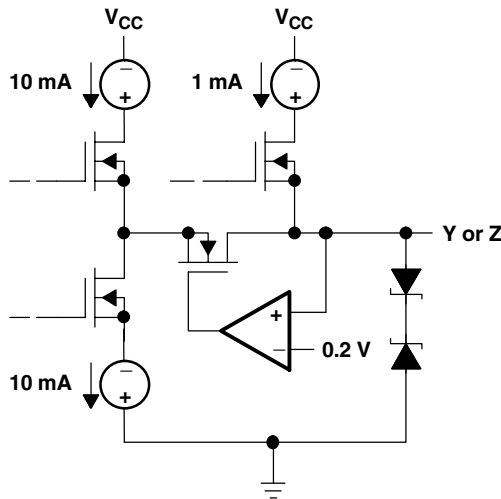

**ACTIVE-LOW ENABLE**

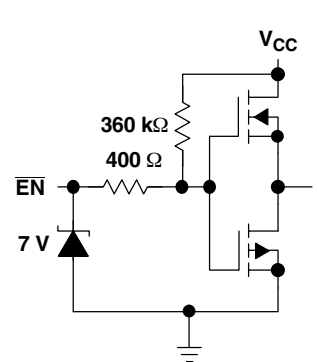

TYPICAL CHARACTERISTICS

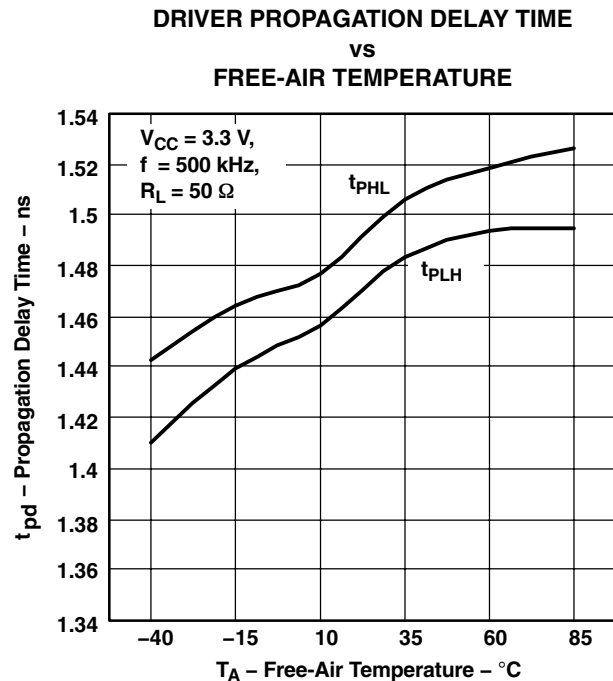
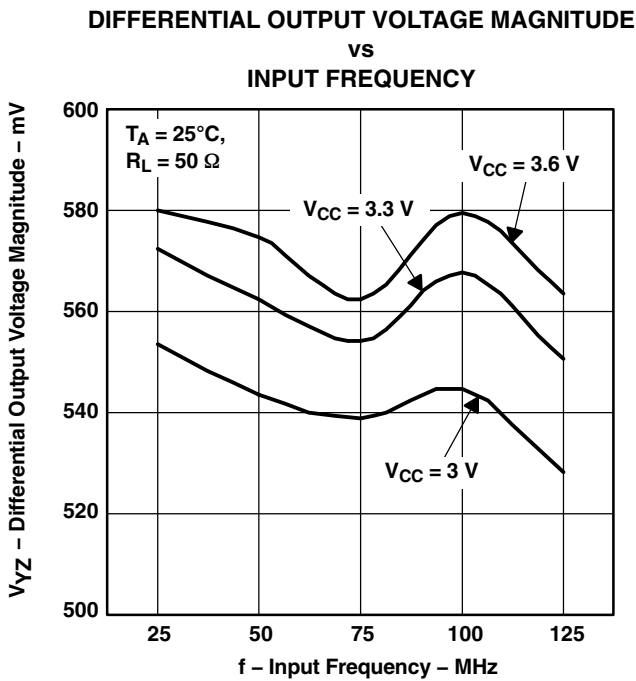
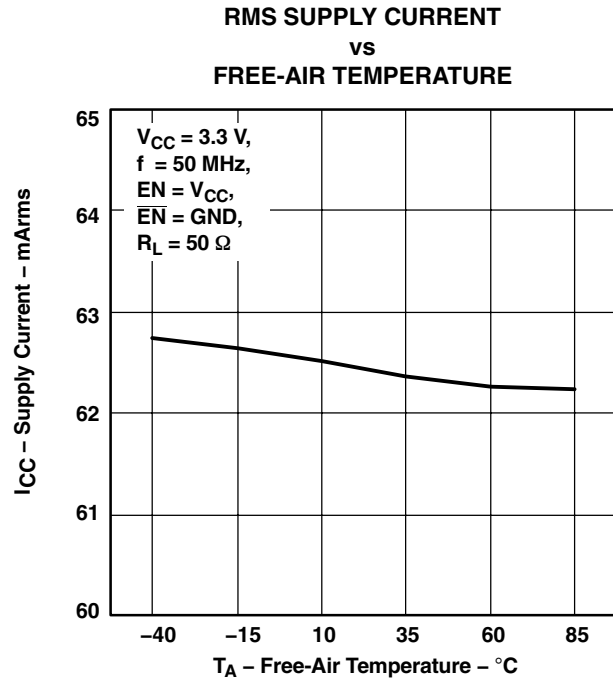
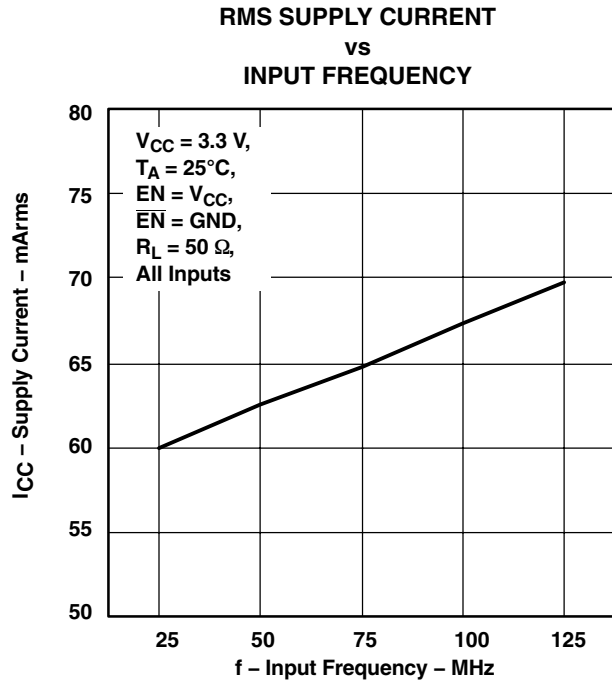

TYPICAL CHARACTERISTICS

DRIVER TRANSITION TIME  
vs  
FREE-AIR TEMPERATURE

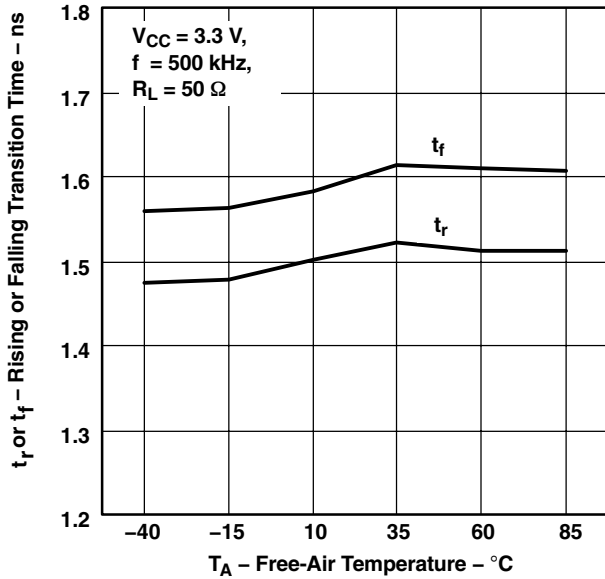

Figure 13

PEAK-TO-PEAK JITTER  
vs  
DATA RATE

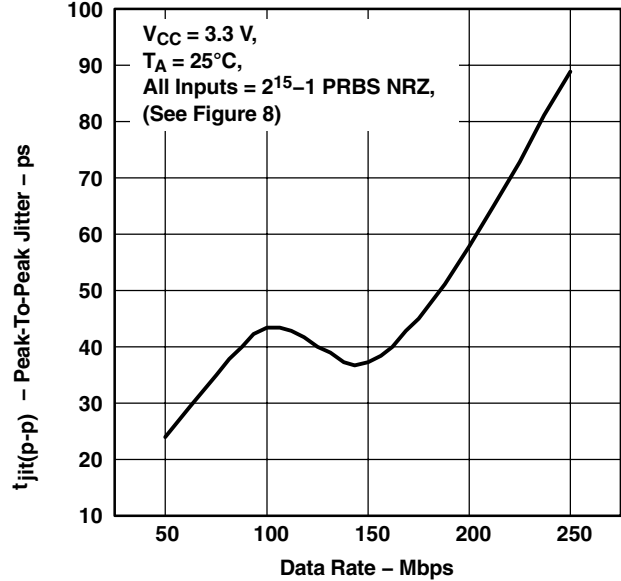

Figure 14

PERIOD JITTER  
vs  
CLOCK FREQUENCY

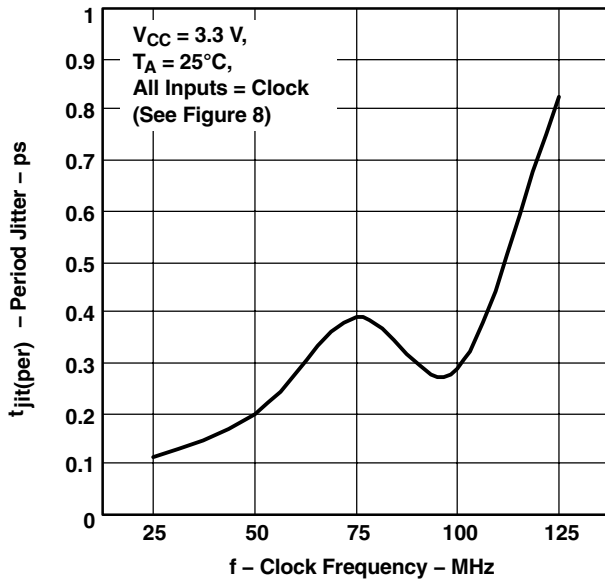

Figure 15

CYCLE-TO-CYCLE JITTER  
vs  
CLOCK FREQUENCY

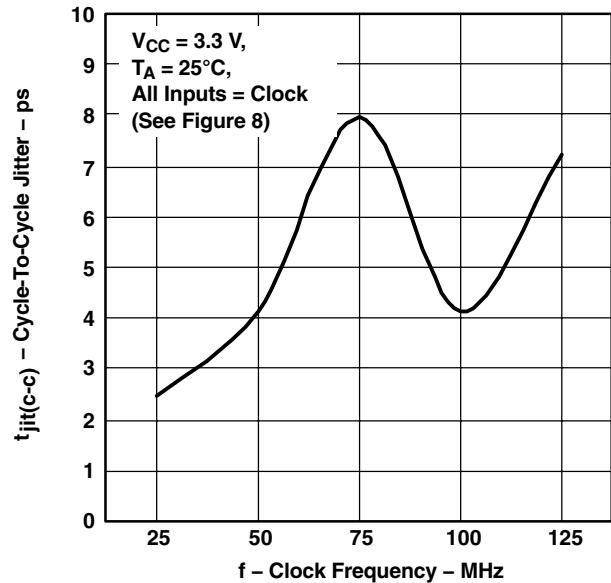

Figure 16

## APPLICATION INFORMATION

### SYNCHRONIZATION CLOCK IN ADVANCEDTCA

Advanced Telecommunications Computing Architecture, also known as AdvancedTCA, is an open architecture to meet the needs of the rapidly changing communications network infrastructure. M-LVDS based clocking is recommended by the ATCA.

The ATCA specification includes requirements for three redundant clock signals. An 8-KHz and a 19.44-MHz clock signal, as well as an user-defined clock signal are included in the specification. The SN65MLVD047A quad driver supports distribution of these three ATCA clock signals, supporting operation beyond 100 MHz, which is the highest clock frequency included in the ATCA specification. A pair of SN65MLVD047A devices can be used to support the ATCA redundancy requirements.

### MULTIPOINT CONFIGURATION

The SN65MLVD047A is designed to meet or exceed the requirement of the TIA/EIA-899 (M-LVDS) standard, which allows multipoint communication on a shared bus.

Multipoint is a bus configuration with multiple drivers and receivers present. An example is shown in Figure 17. The figure shows transceivers interfacing to the bus, but a combination of drivers, receivers, and transceivers is also possible. Termination resistors need to be placed on each end of the bus, with the termination resistor value matched to the loaded bus impedance.

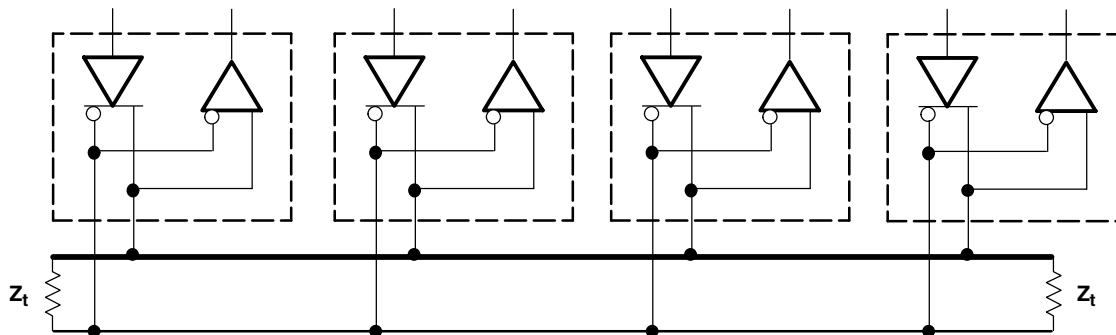
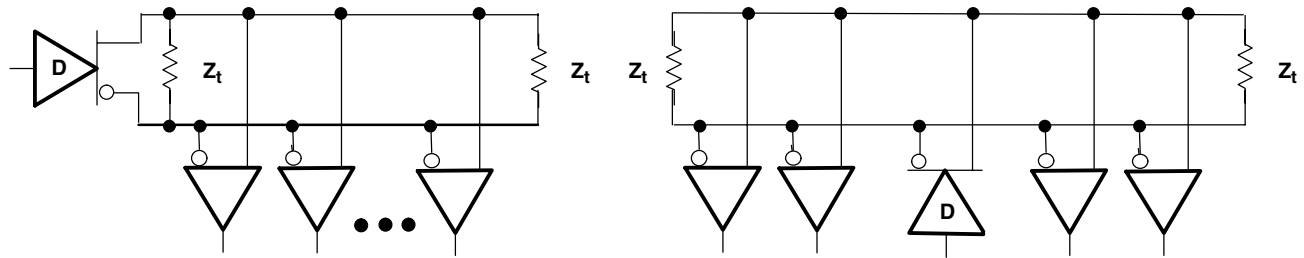

Figure 17. Multipoint Architecture

### MULTIDROP CONFIGURATION

Multidrop configuration is similar to multipoint configuration, but only one driver is present on the bus. A multidrop system can be configured with the driver at one end of the bus, or in the middle of the bus. When a driver is located at one end, a single termination resistor is located at the far end, close to the last receiver on the bus. Alternatively, the driver can be located in the middle of the bus, to reduce the maximum flight time. With a centrally located driver, termination resistors are located at each end of the bus. In both cases the termination resistor value should be matched to the loaded bus impedance. Figure 18 shows examples of both cases.



**Figure 18. Multidrop Architectures With Different Driver Locations**

### UNUSED CHANNEL

A 360-k $\Omega$  pull-down resistor is built in every LVTTL input. The unused driver inputs should be left floating or connected to ground. The low-level output of an unused enabled driver may oscillate if left floating and should be connected to ground. If the input is floating or connected to ground, the unused Y (non-inverting) output of an enabled driver should be connected to ground. The unused Z (inverting) should be left floating.

**PACKAGING INFORMATION**

Orderable Device	Status <sup>(1)</sup>	Package Type	Package Drawing	Pins	Package Qty	Eco Plan <sup>(2)</sup>	Lead/Ball Finish	MSL Peak Temp <sup>(3)</sup>
SN65MLVD047AD	ACTIVE	SOIC	D	16	40	Green (RoHS & no Sb/Br)	CU NIPDAU	Level-1-260C-UNLIM
SN65MLVD047ADG4	ACTIVE	SOIC	D	16	40	Green (RoHS & no Sb/Br)	CU NIPDAU	Level-1-260C-UNLIM
SN65MLVD047ADR	ACTIVE	SOIC	D	16	2500	Green (RoHS & no Sb/Br)	CU NIPDAU	Level-1-260C-UNLIM
SN65MLVD047ADRG4	ACTIVE	SOIC	D	16	2500	Green (RoHS & no Sb/Br)	CU NIPDAU	Level-1-260C-UNLIM
SN65MLVD047APW	ACTIVE	TSSOP	PW	16	90	Green (RoHS & no Sb/Br)	CU NIPDAU	Level-1-260C-UNLIM
SN65MLVD047APWG4	ACTIVE	TSSOP	PW	16	90	Green (RoHS & no Sb/Br)	CU NIPDAU	Level-1-260C-UNLIM
SN65MLVD047APWR	ACTIVE	TSSOP	PW	16	2000	Green (RoHS & no Sb/Br)	CU NIPDAU	Level-1-260C-UNLIM
SN65MLVD047APWRG4	ACTIVE	TSSOP	PW	16	2000	Green (RoHS & no Sb/Br)	CU NIPDAU	Level-1-260C-UNLIM

<sup>(1)</sup> The marketing status values are defined as follows:

**ACTIVE:** Product device recommended for new designs.

**LIFEBUY:** TI has announced that the device will be discontinued, and a lifetime-buy period is in effect.

**NRND:** Not recommended for new designs. Device is in production to support existing customers, but TI does not recommend using this part in a new design.

**PREVIEW:** Device has been announced but is not in production. Samples may or may not be available.

**OBSOLETE:** TI has discontinued the production of the device.

<sup>(2)</sup> Eco Plan - The planned eco-friendly classification: Pb-Free (RoHS), Pb-Free (RoHS Exempt), or Green (RoHS & no Sb/Br) - please check <http://www.ti.com/productcontent> for the latest availability information and additional product content details.

**TBD:** The Pb-Free/Green conversion plan has not been defined.

**Pb-Free (RoHS):** TI's terms "Lead-Free" or "Pb-Free" mean semiconductor products that are compatible with the current RoHS requirements for all 6 substances, including the requirement that lead not exceed 0.1% by weight in homogeneous materials. Where designed to be soldered at high temperatures, TI Pb-Free products are suitable for use in specified lead-free processes.

**Pb-Free (RoHS Exempt):** This component has a RoHS exemption for either 1) lead-based flip-chip solder bumps used between the die and package, or 2) lead-based die adhesive used between the die and leadframe. The component is otherwise considered Pb-Free (RoHS compatible) as defined above.

**Green (RoHS & no Sb/Br):** TI defines "Green" to mean Pb-Free (RoHS compatible), and free of Bromine (Br) and Antimony (Sb) based flame retardants (Br or Sb do not exceed 0.1% by weight in homogeneous material)

<sup>(3)</sup> MSL, Peak Temp. -- The Moisture Sensitivity Level rating according to the JEDEC industry standard classifications, and peak solder temperature.

**Important Information and Disclaimer:**The information provided on this page represents TI's knowledge and belief as of the date that it is provided. TI bases its knowledge and belief on information provided by third parties, and makes no representation or warranty as to the accuracy of such information. Efforts are underway to better integrate information from third parties. TI has taken and continues to take reasonable steps to provide representative and accurate information but may not have conducted destructive testing or chemical analysis on incoming materials and chemicals. TI and TI suppliers consider certain information to be proprietary, and thus CAS numbers and other limited information may not be available for release.

In no event shall TI's liability arising out of such information exceed the total purchase price of the TI part(s) at issue in this document sold by TI to Customer on an annual basis.

**TAPE AND REEL INFORMATION**



**QUADRANT ASSIGNMENTS FOR PIN 1 ORIENTATION IN TAPE**



\*All dimensions are nominal

Device	Package Type	Package Drawing	Pins	SPQ	Reel Diameter (mm)	Reel Width W1 (mm)	A0 (mm)	B0 (mm)	K0 (mm)	P1 (mm)	W (mm)	Pin1 Quadrant
SN65MLVD047ADR	SOIC	D	16	2500	330.0	16.4	6.5	10.3	2.1	8.0	16.0	Q1
SN65MLVD047APWR	TSSOP	PW	16	2000	330.0	12.4	6.67	5.4	1.6	8.0	12.0	Q1

**TAPE AND REEL BOX DIMENSIONS**



\*All dimensions are nominal

Device	Package Type	Package Drawing	Pins	SPQ	Length (mm)	Width (mm)	Height (mm)
SN65MLVD047ADR	SOIC	D	16	2500	346.0	346.0	33.0
SN65MLVD047APWR	TSSOP	PW	16	2000	346.0	346.0	29.0



PW (R-PDSO-G\*\*)

PLASTIC SMALL-OUTLINE PACKAGE

14 PINS SHOWN



4040064/F 01/97

- NOTES: A. All linear dimensions are in millimeters.  
 B. This drawing is subject to change without notice.  
 C. Body dimensions do not include mold flash or protrusion not to exceed 0,15.  
 D. Falls within JEDEC MO-153

D (R-PDSO-G16)

PLASTIC SMALL-OUTLINE PACKAGE

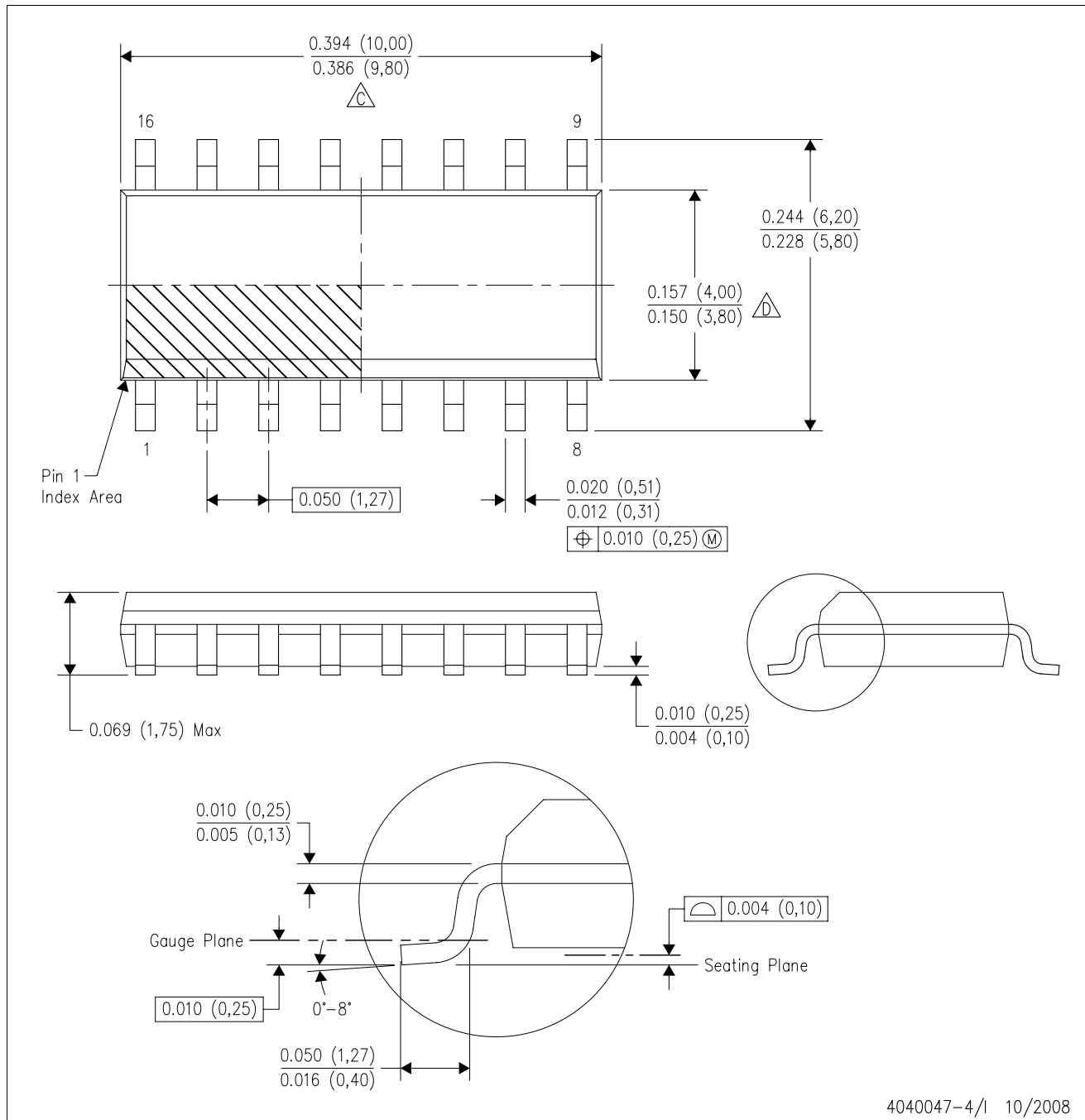

- NOTES:
- A. All linear dimensions are in inches (millimeters).
  - B. This drawing is subject to change without notice.
  - C. Body length does not include mold flash, protrusions, or gate burrs. Mold flash, protrusions, or gate burrs shall not exceed .006 (0,15) per end.
  - D. Body width does not include interlead flash. Interlead flash shall not exceed .017 (0,43) per side.
  - E. Reference JEDEC MS-012 variation AC.

D(R-PDSO-G16)

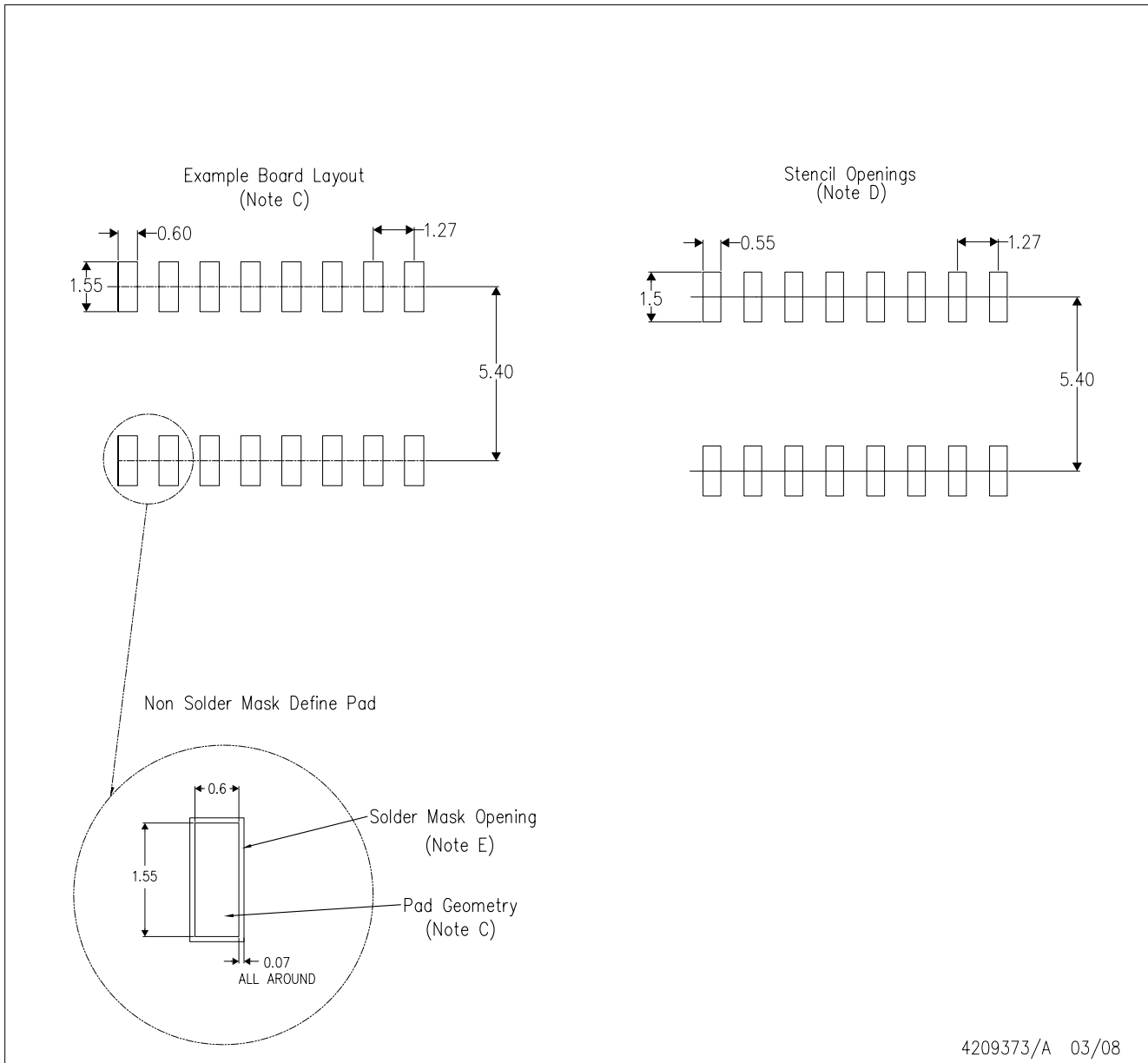

4209373/A 03/08

- NOTES:
- A. All linear dimensions are in millimeters.
  - B. This drawing is subject to change without notice.
  - C. Refer to IPC7351 for alternate board design.
  - D. Laser cutting apertures with trapezoidal walls and also rounding corners will offer better paste release. Customers should contact their board assembly site for stencil design recommendations. Refer to IPC-7525
  - E. Customers should contact their board fabrication site for solder mask tolerances between and around signal pads.

## IMPORTANT NOTICE

Texas Instruments Incorporated and its subsidiaries (TI) reserve the right to make corrections, modifications, enhancements, improvements, and other changes to its products and services at any time and to discontinue any product or service without notice. Customers should obtain the latest relevant information before placing orders and should verify that such information is current and complete. All products are sold subject to TI's terms and conditions of sale supplied at the time of order acknowledgment.

TI warrants performance of its hardware products to the specifications applicable at the time of sale in accordance with TI's standard warranty. Testing and other quality control techniques are used to the extent TI deems necessary to support this warranty. Except where mandated by government requirements, testing of all parameters of each product is not necessarily performed.

TI assumes no liability for applications assistance or customer product design. Customers are responsible for their products and applications using TI components. To minimize the risks associated with customer products and applications, customers should provide adequate design and operating safeguards.

TI does not warrant or represent that any license, either express or implied, is granted under any TI patent right, copyright, mask work right, or other TI intellectual property right relating to any combination, machine, or process in which TI products or services are used. Information published by TI regarding third-party products or services does not constitute a license from TI to use such products or services or a warranty or endorsement thereof. Use of such information may require a license from a third party under the patents or other intellectual property of the third party, or a license from TI under the patents or other intellectual property of TI.

Reproduction of TI information in TI data books or data sheets is permissible only if reproduction is without alteration and is accompanied by all associated warranties, conditions, limitations, and notices. Reproduction of this information with alteration is an unfair and deceptive business practice. TI is not responsible or liable for such altered documentation. Information of third parties may be subject to additional restrictions.

Resale of TI products or services with statements different from or beyond the parameters stated by TI for that product or service voids all express and any implied warranties for the associated TI product or service and is an unfair and deceptive business practice. TI is not responsible or liable for any such statements.

TI products are not authorized for use in safety-critical applications (such as life support) where a failure of the TI product would reasonably be expected to cause severe personal injury or death, unless officers of the parties have executed an agreement specifically governing such use. Buyers represent that they have all necessary expertise in the safety and regulatory ramifications of their applications, and acknowledge and agree that they are solely responsible for all legal, regulatory and safety-related requirements concerning their products and any use of TI products in such safety-critical applications, notwithstanding any applications-related information or support that may be provided by TI. Further, Buyers must fully indemnify TI and its representatives against any damages arising out of the use of TI products in such safety-critical applications.

TI products are neither designed nor intended for use in military/aerospace applications or environments unless the TI products are specifically designated by TI as military-grade or "enhanced plastic." Only products designated by TI as military-grade meet military specifications. Buyers acknowledge and agree that any such use of TI products which TI has not designated as military-grade is solely at the Buyer's risk, and that they are solely responsible for compliance with all legal and regulatory requirements in connection with such use.

TI products are neither designed nor intended for use in automotive applications or environments unless the specific TI products are designated by TI as compliant with ISO/TS 16949 requirements. Buyers acknowledge and agree that, if they use any non-designated products in automotive applications, TI will not be responsible for any failure to meet such requirements.

Following are URLs where you can obtain information on other Texas Instruments products and application solutions:

### Products

Amplifiers	<a href="http://amplifier.ti.com">amplifier.ti.com</a>
Data Converters	<a href="http://dataconverter.ti.com">dataconverter.ti.com</a>
DSP	<a href="http://dsp.ti.com">dsp.ti.com</a>
Clocks and Timers	<a href="http://www.ti.com/clocks">www.ti.com/clocks</a>
Interface	<a href="http://interface.ti.com">interface.ti.com</a>
Logic	<a href="http://logic.ti.com">logic.ti.com</a>
Power Mgmt	<a href="http://power.ti.com">power.ti.com</a>
Microcontrollers	<a href="http://microcontroller.ti.com">microcontroller.ti.com</a>
RFID	<a href="http://www.ti-rfid.com">www.ti-rfid.com</a>
RF/IF and ZigBee® Solutions	<a href="http://www.ti.com/lprf">www.ti.com/lprf</a>

### Applications

Audio	<a href="http://www.ti.com/audio">www.ti.com/audio</a>
Automotive	<a href="http://www.ti.com/automotive">www.ti.com/automotive</a>
Broadband	<a href="http://www.ti.com/broadband">www.ti.com/broadband</a>
Digital Control	<a href="http://www.ti.com/digitalcontrol">www.ti.com/digitalcontrol</a>
Medical	<a href="http://www.ti.com/medical">www.ti.com/medical</a>
Military	<a href="http://www.ti.com/military">www.ti.com/military</a>
Optical Networking	<a href="http://www.ti.com/opticalnetwork">www.ti.com/opticalnetwork</a>
Security	<a href="http://www.ti.com/security">www.ti.com/security</a>
Telephony	<a href="http://www.ti.com/telephony">www.ti.com/telephony</a>
Video & Imaging	<a href="http://www.ti.com/video">www.ti.com/video</a>
Wireless	<a href="http://www.ti.com/wireless">www.ti.com/wireless</a>

Mailing Address: Texas Instruments, Post Office Box 655303, Dallas, Texas 75265  
Copyright © 2008, Texas Instruments Incorporated